

Interpolated DDS Technique in SDG2000X

October 24, 2017

Preface

As can be seen in the data sheet for Siglent’s SDG2000X arbitrary waveform generator series, the sampling rate specification (1.2 GSa/s) is followed by a note of “4X Interpolation”.

Sampling rate	1.2 GSa/s <u>(4X Interpolation)</u>
Vertical resolution	16 bit

This may be confusing to some customers, even some experienced users of function generators. This white paper is intended to explain this specification and to discuss the advantages of the Interpolated DDS technique compared to a traditional DDS based function generator.

Profile of Traditional DDS Systems

The figure below shows the basic design of a traditional DDS system, in which digital waveform data is output in response to a reference clock for the DDS circuitry, then converted by the D/A converter using the same clock. That is to say, in a traditional DDS structure the clock for the DDS and for the D/A converter running at the same frequency.

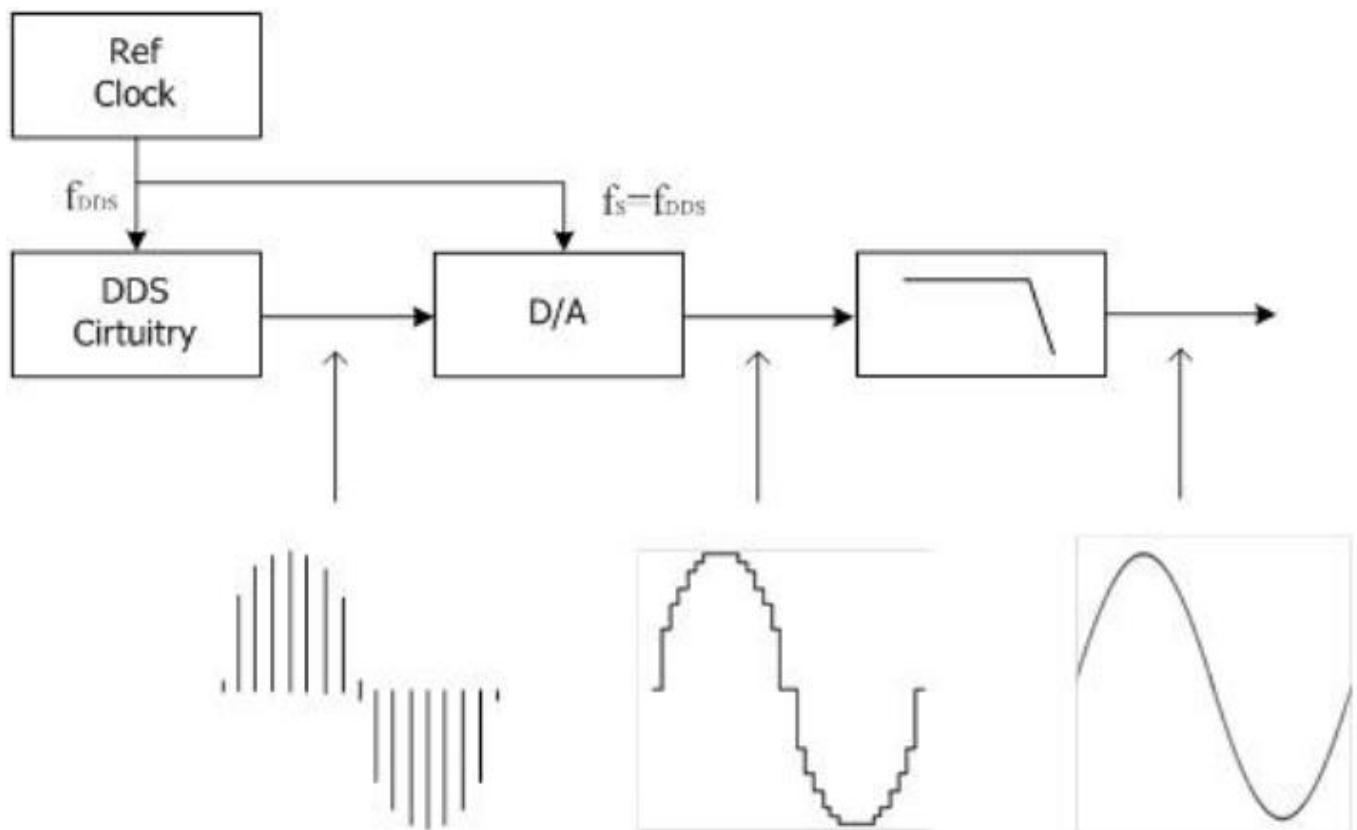

Figure 1 Structure of Traditional DDS

A reconstruction filter following the D/A converter helps to smooth the steps from the D/A's output in order to produce a smoother, more “analog” signal.

Introduction to Interpolated DDS

The figure below shows the structure of the Interpolated DDS. An interpolator is inserted between the DDS circuitry and D/A converter. In this structure, digital waveform data is output in response to the reference clock of the DDS circuitry, interpolated by “I” (in SDG2000X I = 4), and then converted by the D/A, with a sampling clock “I” times the frequency of the reference clock. After the D/A converter, a reconstruction filter is also applied.

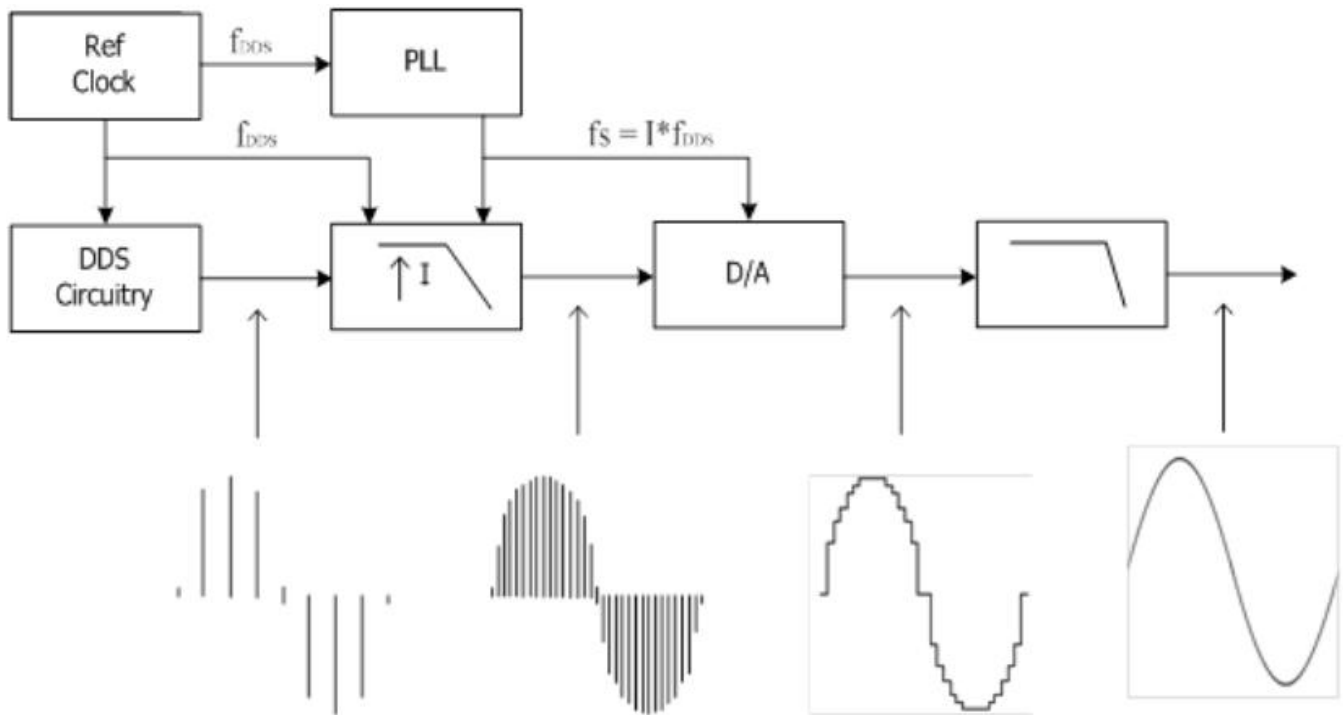

Figure 2 Structure of Interpolated DDS

Siglent’s SDG2000X applies this technique with the interpolation factor I = 4. The reference clock of the DDS circuitry on the SDG2000X is 300 MHz. Using the interpolation circuitry, the sampling clock of the D/A converter is increased to 1.2 GHz. This is the explanation behind 1.2 GSa/s specification found in the data sheet - 1.2 GSa/s followed by a “4X interpolation” note.

This explains the mechanics behind the interpolated sampling technique. However, what is the technical reasoning behind Siglent’s innovative sampling technique?

Why Interpolation?

4.1 To Break the Bandwidth Limit

First, let’s compare the waveform in the time domain using the two different sample rates. Looking at the output waveform of the D/A, the 1.2 GSa/s sample rate results in smaller steps (higher resolution) than with the 300 MSa/s sampling clock (Fig 3).

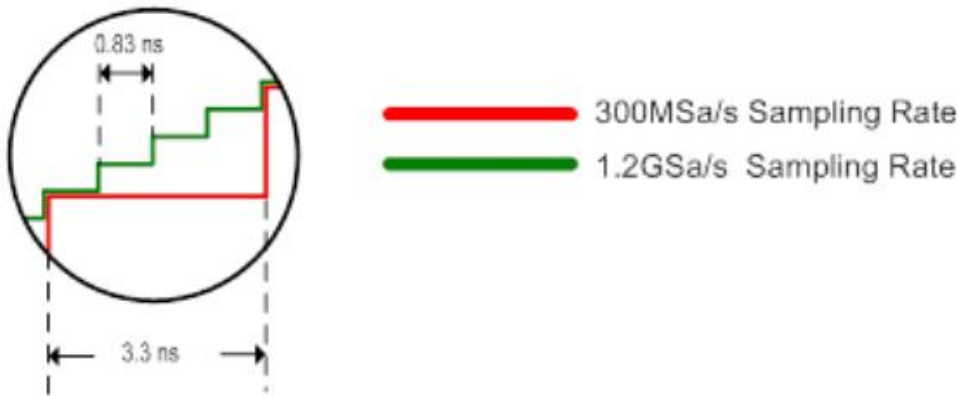

The reader may ask, “If both waveforms are to be passed through a restructuring filter in order to smooth the waveform steps, then the sample rate should not matter.” The fact is, the step size does affect the final smoothed waveform.

Now let’s look at this difference in the frequency domain in order to get a clearer understanding.

The figure below shows a spectrum example in which an 80 MHz sine wave is output by a D/A with 300 MSA/s. Output spectrum of the D/A includes the fundamental, and its image frequencies $N \cdot f_s \pm f_{out}$, $N=1,2,\dots$. Amplitudes of all the spectrum components comply with the $\sin(x)/x$ envelope. Usage of the reconstruction filter is to filter all of the image frequencies which are located outside the Nyquist bandwidth.

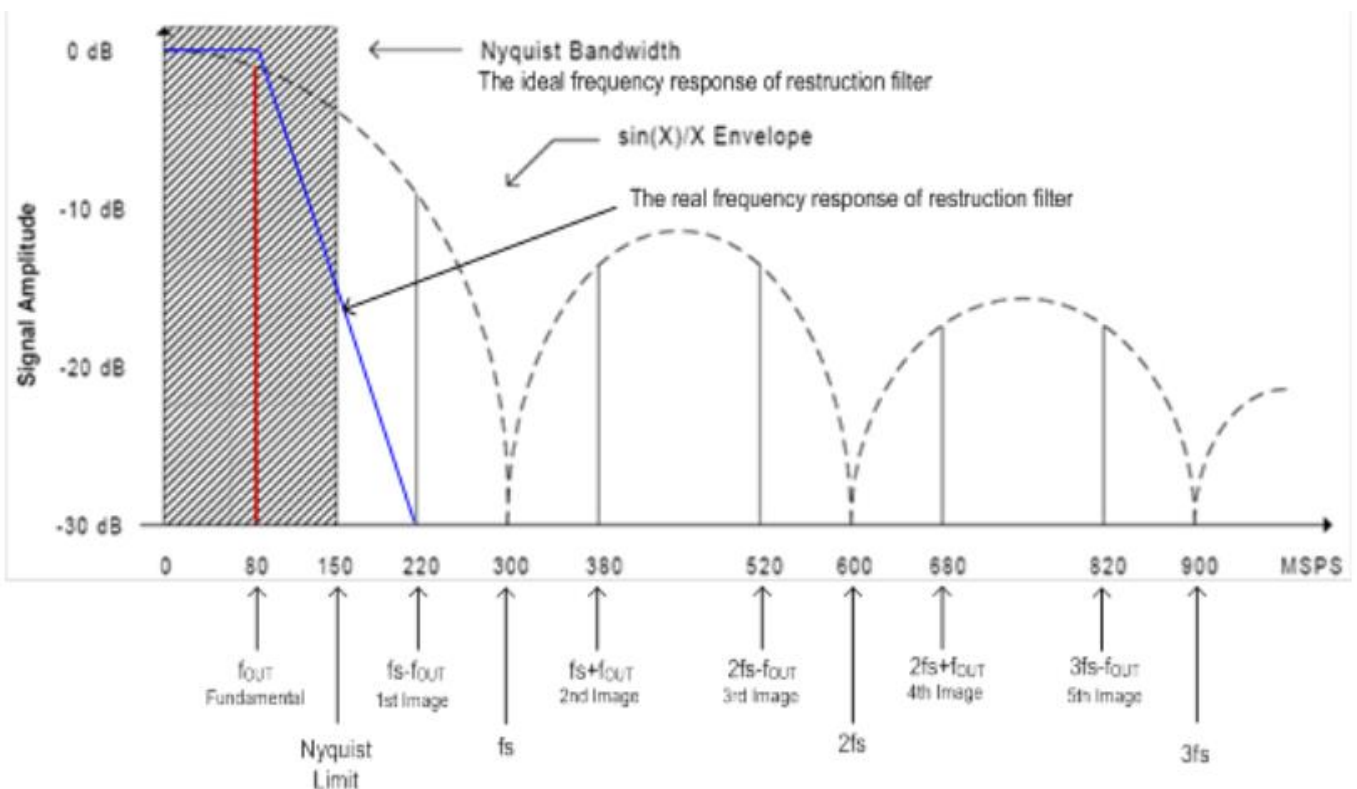

Figure 4 Spectrum of 300 MSA/s D/A, 80 MHz Output

An ideal reconstruction filter should retain all the signals located in the Nyquist bandwidth, and filter out

the ones outside it. In other words, its frequency response should be coincident with the Nyquist bandwidth, as the shadow part in Figure 4. In this case, the maximum frequency can reach the Nyquist Limit (e.g. 1/2 sampling clock frequency).

As we know, in engineering the ideal filter with “brick wall” response doesn’t exist. In the real world, filters actually have some degree of roll off.

Figure 4 shows the spectrum of the output from a 300 MSa/s A/D converter with an output frequency of 80 MHz. The nearest image occurs at 220 MHz so the maximum roll-off would occur at 140 MHz. But for a 150 MHz signal, the nearest image is $300 - 150 = 150$ MHz, the space remaining for roll-off is zero, which is not realizable. Generally, the limit bandwidth of a reconstruction filter is 40% of the sampling clock. That is to say, for a 300 MSa/s D/A, the maximum available output frequency is 120 MHz.

The figure below shows 2 reconstruction filter designs with roll offs from 120 MHz to 180 MHz. Both designs are 9-order elliptic filters. The difference is the design on the left uses ideal components, and the one on the right uses real-world components, with parasitic parameters. As we can see, a real filter has an extra ~3dB attenuation on the corner frequency (i.e. 120 MHz), and its attenuation performance on the stop band cutoff frequency (i.e. 180 MHz) degrades.

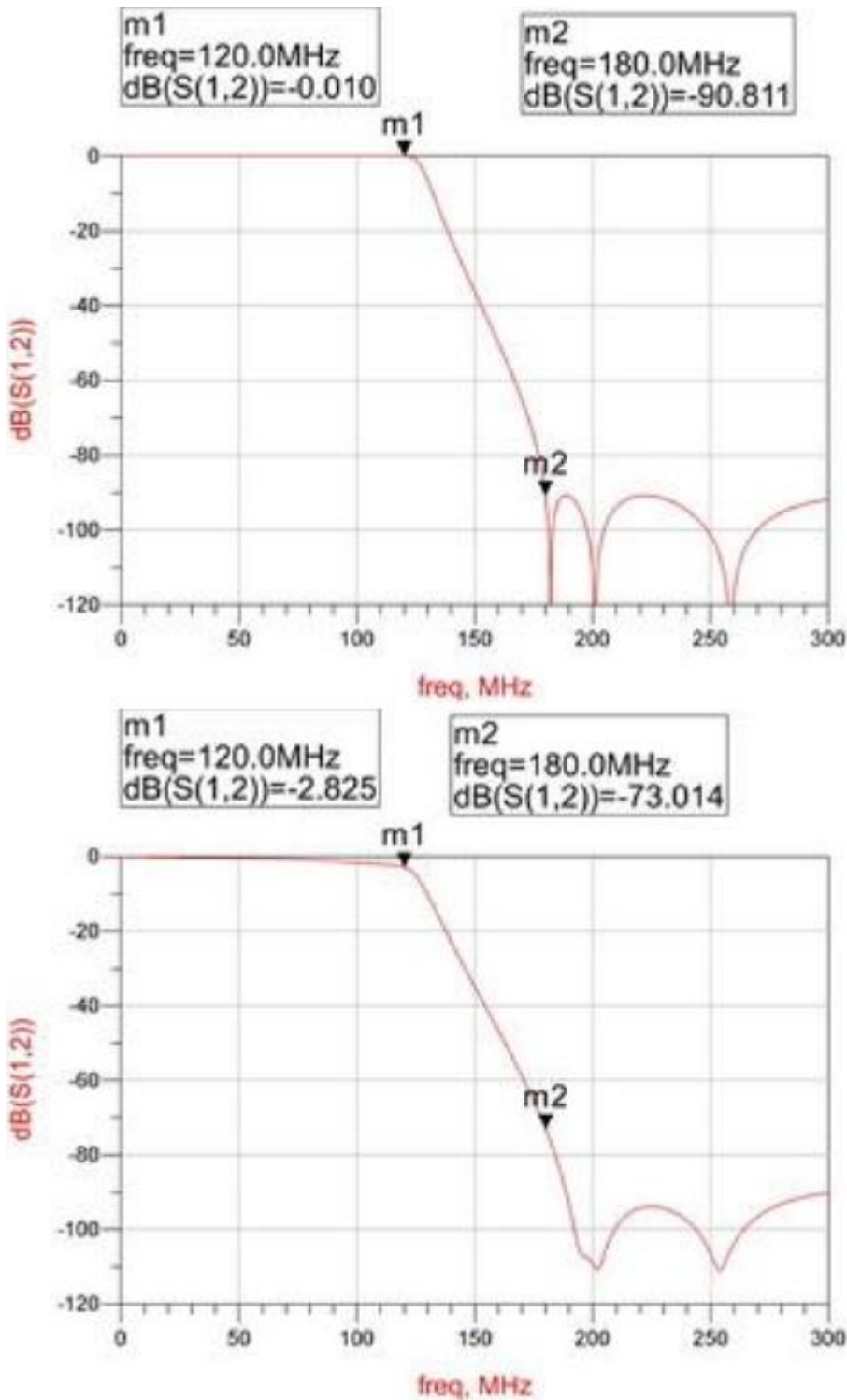

Figure 5 Reconstruction Filter Design with Ideal Components V.S. with Real Components

In addition, the $\sin(x)/x$ envelope of the D/A's response itself will add attenuation to the signal. At 40% of the sampling clock (e.g. 120 MHz in Figure 4), the attenuation caused by the D/A is about 2.4 dB. An inverse $\sin(x)/x$ filter is generally necessary to compensate this attenuation.

If the sampling rate of D/A is 1.2 GSa/s, for a 80 MHz signal, the nearest image is 1.12 GHz, so the maximum roll off of reconstruction filter could be 1.04 GHz, as shown in Figure 6. Design of the

reconstruction filter is greatly simplified.

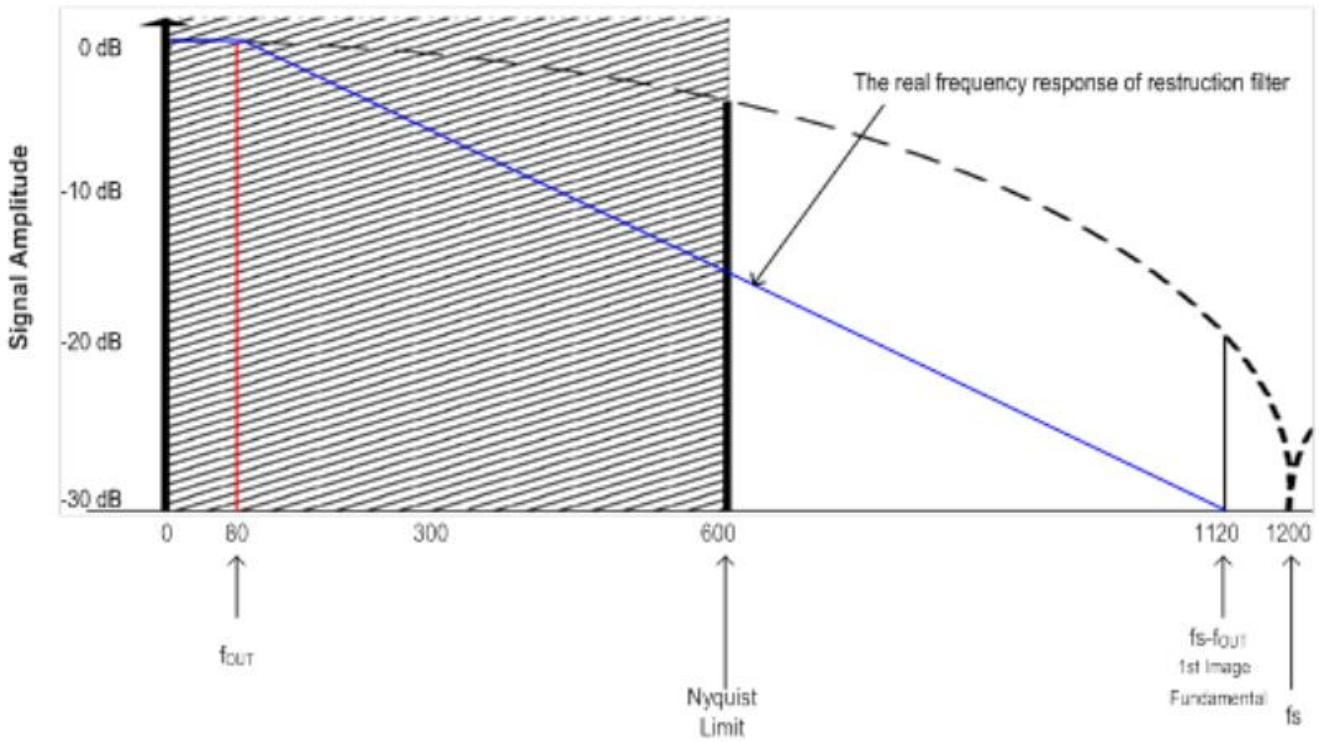

Figure 6 Spectrum of 1.2 GSa/s D/A, 80 MHz Output

Figure 7 shows the real reconstruction filter design with roll off from 120 MHz to 1.08 GHz. This is much easier to achieve than the one with roll off from 120 MHz to 180 MHz.



On the other hand, as the main lobe width of the $\sin(x)/x$ envelope increases, the attenuation contributed by the D/A decreases. At 120 MHz, the attenuation caused by the 1.2 GSa/s D/A is approximately 0.14 dB, which can be ignored in most cases. No more inverse $\sin(x)/x$ filtering is needed.

Based on the above, because of limits of the reconstruction filter a 300 MSa/s D/A can only output a 120 MHz maximum frequency. But a 1.2 GSa/s D/A can achieve a higher upper frequency limit. Of course in the interpolated DDS structure, the digital filter in the interpolator will restrict the frequency to the Nyquist limit of the DDS clock (e.g. 150 MHz), but a digital filter is much easier to design than an analog reconstruction filter. Using the interpolated DDS, it is easy to raise the upper limit of output frequency from 120 MHz to 130 MHz or more.

4.2 To Remove the Spurs Generated by D/A Converter

Intermodulation distortion is unavoidable in a D/A converter. In a traditional DDS structure, it is difficult to remove some inter-modulation distortion components between the clock and the output signal, such as $f_s - 2f_{out}$, $f_s - 3f_{out}$. The figure below shows an example with 120 MHz output frequency and 300 MSa/s sampling rate. The distortion = $f_s - 2f_{out} = 60$ MHz falls into the passband of the reconstruction filter. It is not possible to be removed.

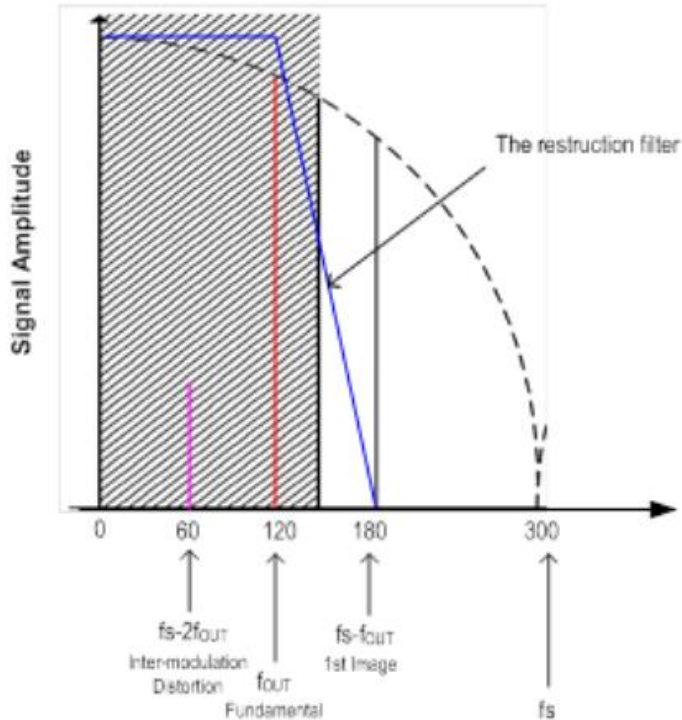

But with a 4X interpolated DDS structure, for 120 MHz frequency output, the distortion components = $f_s - 2f_{out} = 960$ MHz, $f_s - f_{out} = 840$ MHz, which are located far away from passband of the reconstruction filter.

Summary

Compared with a traditional DDS design, the Interpolated DDS technique inserts an interpolator between the DDS circuitry and the D/A converter, yielding a higher sampling rate. With such a structure the design of the reconstruction filter is no longer the bottleneck for bandwidth. On the other hand, the problems due to intermodulation distortion products falling into the passband of the reconstruction filter is solved, resulting in better SFDR performance.

Reference

- [1] Analog Devices, A Technical Tutorial on Digital Signal Synthesis
- [2] A.V. Oppenheim, R.W. Schaffer, J.R. Buck, Discrete-time Signal Processing



North American Headquarters

SIGLENT Technologies NA
6557 Cochran Rd Solon, Ohio 44139
Tel: 440-398-5800
Toll Free: 877-515-5551
Fax: 440-399-1211
info@siglent.com
www.siglentamerica.com/

European Sales Offices

SIGLENT TECHNOLOGIES GERMANY GmbH
Liebigstrasse 2-20, Gebaeude 14,
22113 Hamburg Germany
Tel: +49(0)40-819-95946
Fax: +49(0)40-819-95947
info-eu@siglent.com
www.siglenteu.com

Asian Headquarters

SIGLENT TECHNOLOGIES CO., LTD.
Blog No.4 & No.5, Antongda Industrial Zone,
3rd Liuxian Road, Bao'an District,
Shenzhen, 518101, China.
Tel: + 86 755 3661 5186
Fax: + 86 755 3359 1582
sales@siglent.com
www.siglent.com/ens